



WALRUS
PUMP

HQ_B Series

Electronic Control Pump



**Better Life
Through Innovation**

HQ_B Series Electronic Control Pump

50 Hz

Power: 0.18 - 0.75 kW

Head: Up to 33 M

Flow: Up to 110 L/min

Outlet: 1"

Inlet: 1"



Construction Industry



Agriculture & Fishing Industry



Manufacturing Industry



Electricity & New Energy Industry



Entertainment & Leisure Industry



Accommodation & Food Service Industry



Wholesale & Retail Industry



Water Supply & Pollution Control



Service Industry



Product Features

- The HQ_B is a complete, all-in-one unit, consisting of pump, motor, pressure tank, and electronic controller. The built-in electronic controller provides constant pressure which ensures that the pump starts automatically when water is consumed and operates continuously until water is not required.
- Compact design and quiet operation make the HQ_B series suitable for many applications.
- The HQ_B is constructed from the top quality corrosion resistant materials.
- Pump has built in dry-run shut off with automatic reset function.
- The motor has built-in thermal overload to protect against high operating temperatures and over current.
- The HQ_B has an anti-cycling feature which prevents the pump from continuous starting and stopping when you have a dripping tap or minor leak in the system.
- The pumps will lift water up to 7.6m. with foot valve and pump suction piping filled with water.

Operating Conditions

- Ambient Temperature: Max. +40°C
- Liquids Temperature: +4°C ~ +40°C
- System Pressure: Max. 8.5 kg/cm²
- Relative humidity: Max. 85% (RH)
- Under normal operation, it is not necessary to adjust the pressure unless the cut in pressure is higher than preset activation point (refer to specification).

Dimensions

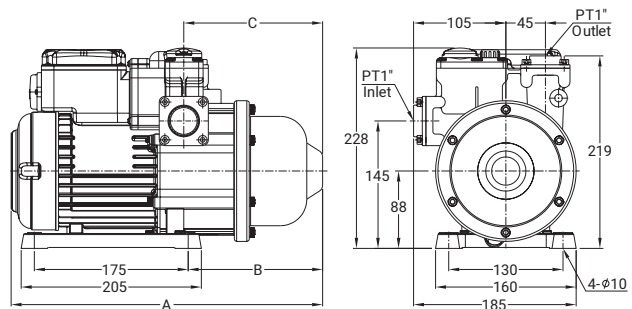

Model	Cycle Hz	A mm	B mm	C mm
HQ200B	50	355	153	158
HQ400B	50	355	153	158
HQ800B	50	410	162	167

Performance Curve

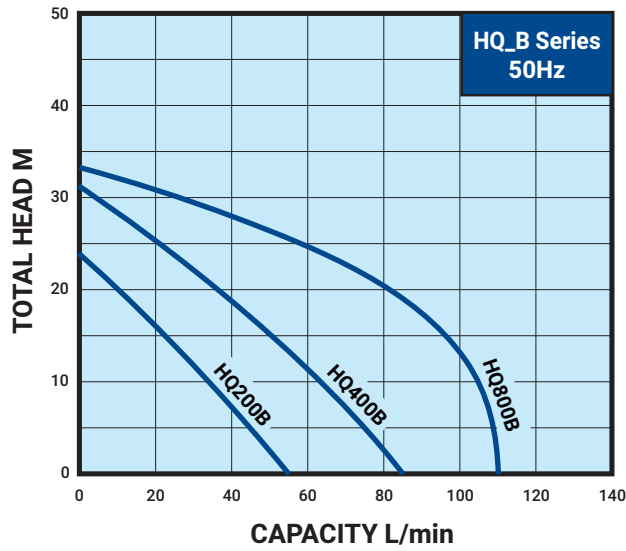

HQ_B Series 50Hz

Model	Power kW	Cycle Hz	Phase \emptyset	Volt V	Amp's A	Inlet in.	Outlet in.	Preset activation point kg/cm ²	H max. m	Q max. L/min	N.W. kg	G.W. kg	
HQ200B	0.18	50	1	200 - 240	1.5	1"	1"	1.6	24	55	7.4	8.0	36
HQ400B	0.37	50	1	200 - 240	2.8	1"	1"	2.0	31	85	8.4	9.0	36
HQ800B	0.75	50	1	200 - 240	4.5	1"	1"	2.0	33	110	10.8	11.4	36



WALRUS
PUMP

N.J.Power & Co. Ltd.

Unit 7, Ballymount Business Park,
Ballymount Road, Dublin 12 Ireland.
Tel : 00353 1 4564099
E-mail : info@njpower.ie.



All specifications are subject to change without notice. HQ_B-EN000b-202410

